

#### TOUCH II

7" touchscreen, user-friendly, programmable  
 USB Connection: PC software free of charge  
 37 languages, continually expanded  
 Upload videos to display, use for ads, instructions, etc.

#### G-FORCE EXTRACTION

25-100 lb capacity washers: 200G  
 135-180 lb capacity washers: 150G  
 Fully programmable



#### CONNECTIVITY

DomusConnect - IoT  
 Provided at NO extra charge  
 Manage your laundry anywhere, at anytime, 24/7  
 Create programs, special promotions, access real-time reports, have service alerts go directly to technicians, and much more.



#### EFFICIENCY

Intelligent consumption, automatically adjusts water and chemicals  
 Low energy and water consumption



#### VERSATILITY

Easily converts from OPL to COIN  
 Electric or Hot Water  
 Wetcleaning ready  
 Extraction speed and water levels easily programmed for applications such as wetcleaning

#### ERGONOMICS

Reversible doors, standard  
 Large doors for easy loading, unloading

#### MAINTENANCE

Hinged front control panel, easy and ergonomic access  
 Technical menu, statistics for technicians  
 Equivalent parts across all models



#### MORE INFO

Hard mount washer  
 Anchor to floor with base (see intallation manual)  
 3 water inlets  
 CE , WRAS approved



#### OPTIONS

- DomusConnect communication kit
- Auto unlock kit for door (in case of power failure) - recommended for vended laundries
- AISI 304 Stainless Steel outer casing
- AISI 304 Stainless Steel top and front panels
- Silicon gasket
- 6 extra dosing signals avail for DLU-25 to DLU-100
- Normally closed drain valve
- Double drain kit for DLU-40/50/65/80C/100C
- Anchoring base
- Ready for EcoTank conn. 1" for washers DLU/DHU 80C/100C
- 230V 3~ 50/60Hz DLU-80C/100C
- Extra dosing pump DB-1
- Sluice - Drum
- Tropicalized model: protected board (TOUCH II)
- Coin/token kit

DRUM	UNIT.	DLU-80C TOUCH II	
Capacity 1/9	Lb.	86	
Capacity 1/10	Lb.	77.2	
Volume	Cu.Ft	12.4	
Diameter	in	33.9	
Depth	In	23.7	
GENERAL DETAILS			
Washing speed / Spinning speed	r.p.m.	45/644	
G Factor	-	200	
Maximum force transmitted	KN	4,59 ±8	
Frequency-dynamic force	Hz	7,58	
Noise level	dB	<70	
Coin laundry version	-	Yes	
Double drain	-	Opt.	
Weighing system / Tilting door	-	No	
SLUICE option	-	Yes	
DOOR			
Height center door / Height door	In	29/17.3	
Diameter	In	22.1	
POWER			
Motor	Hp	5.4	
Electric heating power	kW	21	
Total electric power (electric model)	kW	22	
Total electric power (hw, steam model)	kW	4	
CONNECTIONS		E	HW/S
Voltage 208-240/60/1~ + G	Nº x AWG / A	-	3 x 12 / 20A
Voltage 230/3~ + G	Nº x AWG / A	4 x 6 / 70A	4 x 12 / 20A
Voltage 440-480/3 ~ + G	Nº x AWG / A	4 x 8 / 45A	-
Steam inlet (Steam model)	inch	3/4"	
Maximum steam consumption (Steam model)	Kg/h	18	
Water inlet	inch	3/4"	
Water main pressure	Kgs/cm <sup>2</sup>	2-4	
Maximum water consumption*	Gal/h	52.7*	
Drain	mm/inch	3"	
Drainage capacity	Gal/min	52.8	
DIMENSIONS / PACKING DIMENSIONS			
Net Width/Gross width	In	38.54/41.2	
Net Depth/Gross depth	In	41.97/50.4	
Net Height / Gross height	In	55.55/65.2	
Net weight / Gross weight	Lb.	1049.6/1124.6	
Volume	Ft <sup>3</sup>	77.7	

\* Program No. 20: DLU-25 to DLU-100C with 75% load and program no. 2: DLU-135C and 180C with 100% load

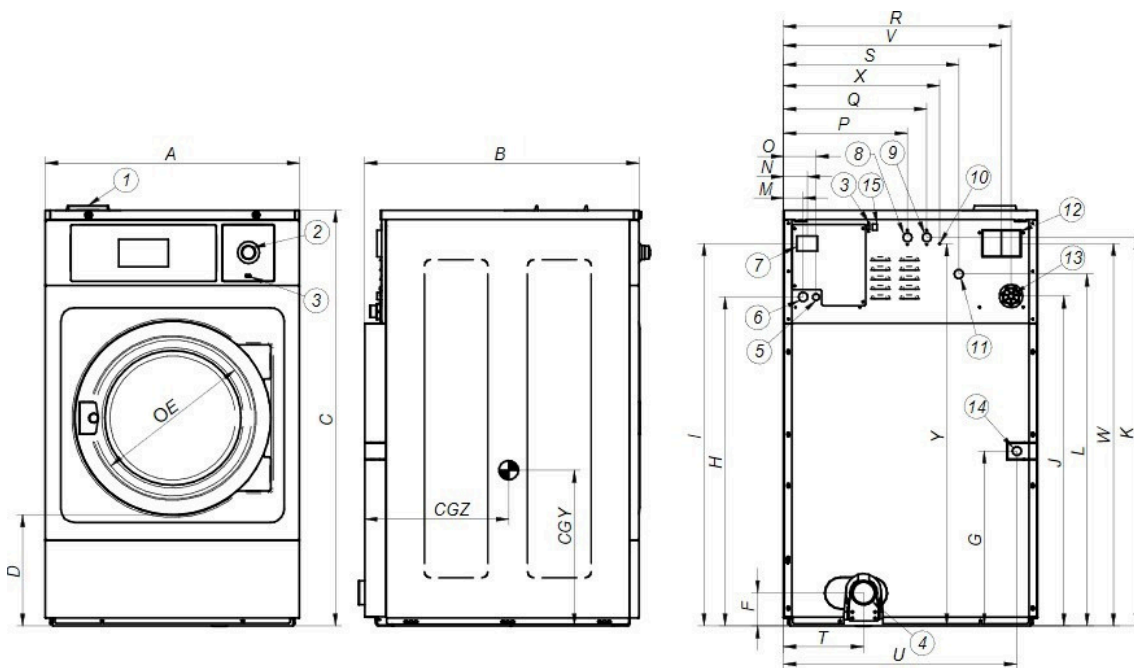

1. Soap dispenser
2. Emergency stop
3. USB port
4. Drain
5. Electric connection to liquid soap pumps
6. Electrical connection
7. Main switch
8. Auxiliary water inlet
9. Hot water inlet
10. Equipotential connection
11. Cold water inlet
12. Water output / Water overload
13. Liquid soap connection
14. Steam connection
15. Ethernet port
16. Clean side light

		A	B	C	D	E	F	G	H	I	J	K	L	M	N	O	P	Q	R	S	T	U	V	W	X	Y	CGY	CGZ
DLU-80C	mm	979	1155	1411	370	560	149	623	1139	1307	1116	1322	1211	61	74	101	544	625	885	715	262	917	855	1281	760	1367	635	682
	inch	38.54	45.47	55.55	14.57	22.05	5.87	24.53	44.84	51.46	43.94	52.05	47.68	2.40	2.91	3.98	21.46	24.61	34.84	28.15	10.31	36.10	33.66	50.43	29.92	53.82	25.00	26.85