



LAUNDRY **SOLUTIONS**  
YOU CAN **DEPEND** ON.

# MAYTAG® COMMERCIAL ENERGY ADVANTAGE™ TOP-LOAD WASHER

## MAT12PRL

### MORE ENERGY-SAVING SOLUTIONS THAN ANY OTHER BRAND

Maytag built the first appliance ever to receive the ENERGY STAR® label. Today we offer more high-efficiency laundry appliances than any other brand — from energy-efficient dryers to highly efficient ENERGY STAR®-qualified washers — to help you save money and build profits.



#### FOR YOUR CUSTOMERS:

- Improved Cleaning Performance
- Debit Cards Mean No Loose-Change Hassles
- Vacuum Fluorescent Display Panel
- Extra-Large Lid And Tub Opening For Easy Loading And Unloading

#### FOR YOUR OPERATION:

- The Most-Efficient, Best-Cleaning Top-Load Washer From Maytag
- Thermistor Water Valve Regulates Water Temperature To Cut Energy Costs
- Super Cycle Option Increases Revenue
- Self-Diagnostic Feature Cuts Service Costs And Minimizes Downtime
- Front Access For Easier Self-Service
- Accu Trac® Audit System With Two-Way Data Communication
- Debit Card Compatibility

#### BUILT-TO-LAST™ FEATURES:

- Premium Porcelain Top
- Quad Coat™ Cabinet Protection
- Dependable Drive® Transmission
- Poly-Pump™ Self-Cleaning Polypropylene Pump Can't Rust
- The Best Warranty In The Business

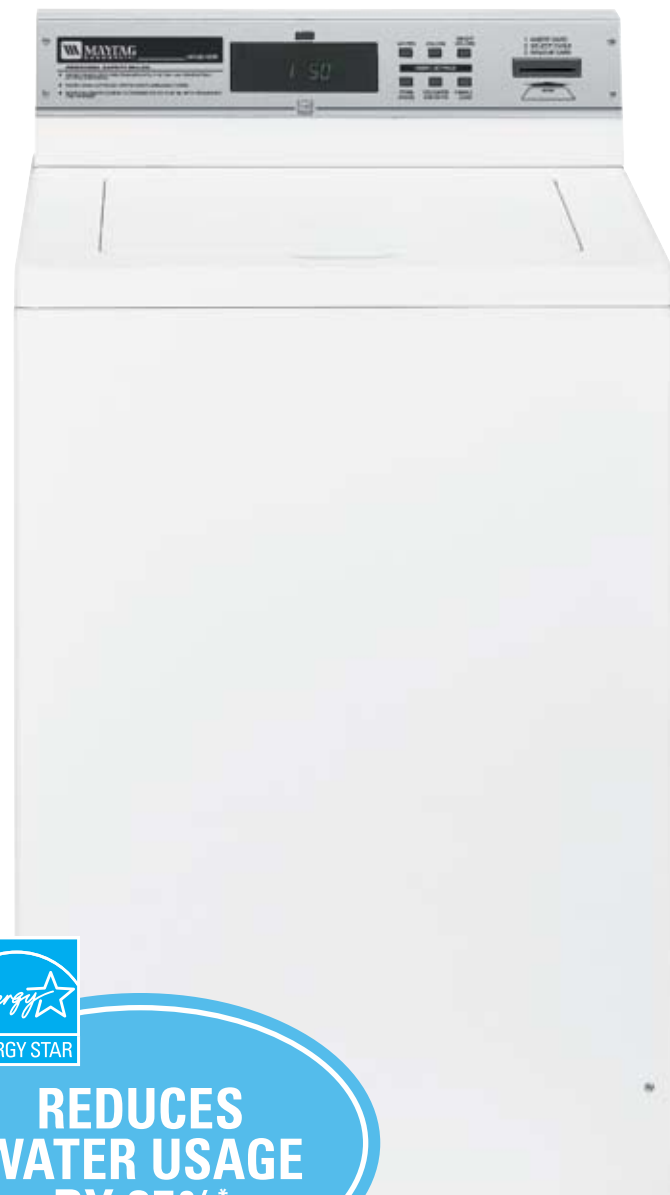

**REDUCES  
WATER USAGE  
BY 25%\***

\* Compared to previous Maytag® Dependable Care top-load washer.

# Maytag® Energy Advantage™ Top-Load Washer

## DEBIT CARD-READY

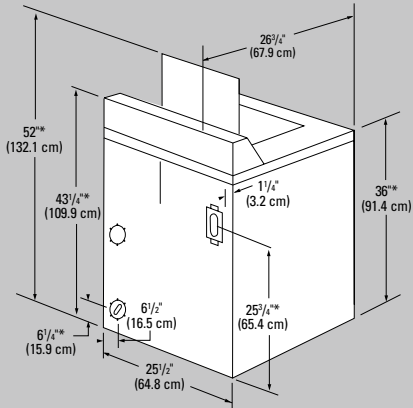

\* Dimensions will vary according to adjustment of leveling legs; add 1/2" (1.3 cm) minimum.



## 5 YEARS — ALL PARTS

For a period from the date of original purchase through the time listed above, the designated parts that fail in normal commercial use will be repaired or replaced free of charge for the part itself, with the owner paying all other costs, including labor, transportation and customs duty. Chemical damage is excluded from all warranty coverage. See complete warranty for details.



### Energy Advantage™ Top-Load Washer

WASHER SPECIFICATIONS	
<b>MODEL</b>	<b>MAT12PRL</b>
<b>MOTOR</b>	
Single-phase, reversible, thermoprotected	•
HP (kw)	1/2 (.37)
<b>APPROXIMATE WATER USAGE</b> — gal. (liters)	
Average hot water usage	2.8 (10.6)*
Average total water usage	23.8 (90)*
<b>ELECTRICAL RATING</b>	120V, 60 Hz
<b>FUSE REQUIREMENT</b>	
Amps	15
<b>CAPACITY</b>	
Volume — cu. ft. (liters)	2 1/2 (70.8)
Diameter — in. (cm)	20 1/2 (52.1)
Depth — in. (cm)	13 (26.75)
<b>LID OPENING</b>	
In. (cm)	16 (40.6)
<b>EXTRACT SPEED</b>	
Maximum rpm	618
Maximum g-force	110
<b>WATER PRESSURE</b>	
Psi (bar)	15 – 120 Psi (1 – 8)
<b>INLET HOSE LENGTH</b>	
Ft. (m)	4 (1.22)
<b>DRAIN HOSE LENGTH</b>	
Ft. (m)	4 (1.22)
<b>ADJUSTABLE LEVELING LEGS</b>	•
<b>COLOR</b>	
White	•
<b>APPROXIMATE WEIGHT</b>	
Crated — lbs. (kg)	224 (102)
Uncrated — lbs. (kg)	198 (90)

\* Average based on J1 testing with factory preset cycles.

Flush-to-wall installation is permitted by a 1 1/2" (3.2 cm) back panel overhang.

See specific instructions for proper installation. Because of continuous product improvement, Maytag reserves the right to change specifications without notice.



NEW YORK CITY  
M.E.A.

